

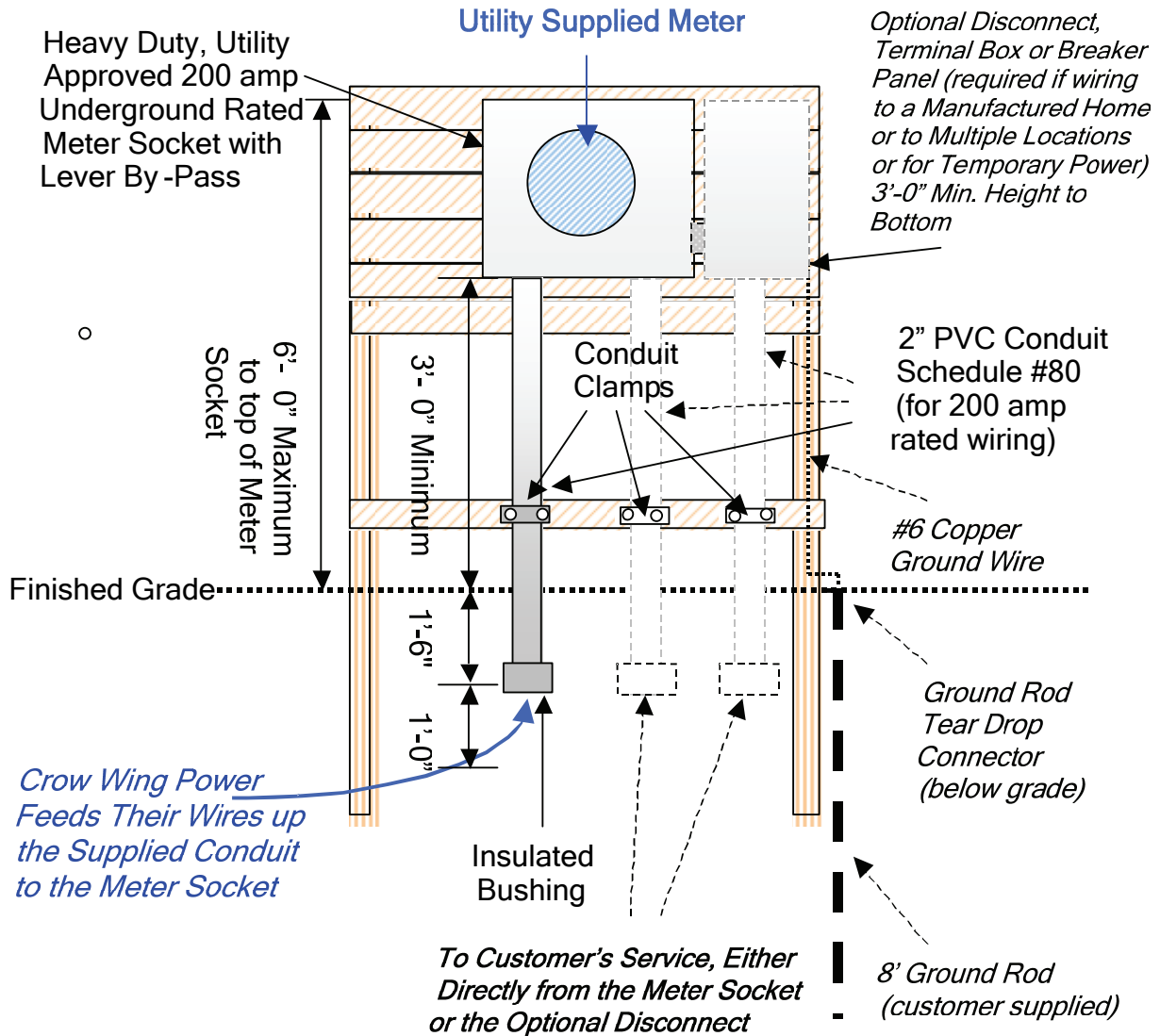

**CUSTOMER SUPPLIED PEDESTAL MOUNTED UNDERGROUND METER ASSEMBLY, RESIDENTIAL, 200 AMP RATED**



**Notes:**

All meter assemblies must be approved by the Minnesota State Board of Electricity prior to energizing by Crow Wing Power.

Lumber to be either fully treated or rot resistant wood such as redwood or cedar.

Uprights shall be minimum 4"x 4" size placed 2'-3' in the ground to avoid frost shifting.

Backing material should be minimum 3/4" thickness.

Hardware to be rust resistant.

Consult with the State Wiring Inspector BEFORE hooking up to a Manufactured or Mobile Home.

## TYPICAL APPLICATIONS

### Underground Service to Meter On Pedestal "Stick-Built" House

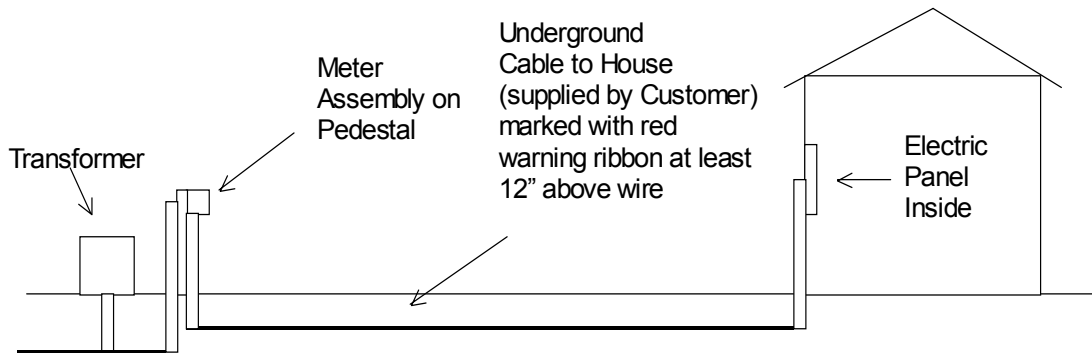

### Underground Service to Meter On Pedestal "Manufactured Home"

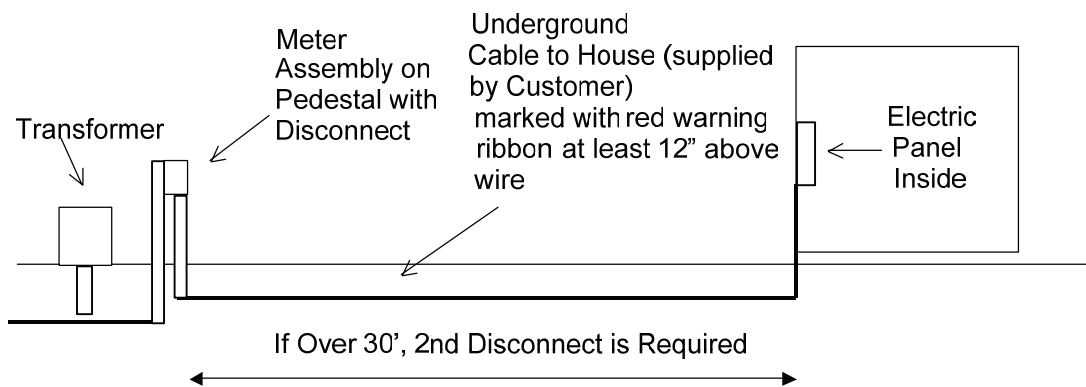

- Customer supplied wiring from the load side of the meter equipment must be sized in accordance with the National Electric Code.
- Wire size of a residential single phase dwelling service can be sized using the table notes for Article 310:15 (B)(6).
- Any secondary residential type service for heating or air conditioning (continuous duty service) are not subject to derating and must be sized from table 310:16. This is for both direct and subtractive metering.
- Red warning ribbon is placed at least 12" above underground wiring.