



HEATING SOURCES FOR YOUR HOME

Here's some information on how to evaluate the best source of heat for your home.

I. BACKGROUND

To maintain a comfortable temperature in your home during the winter requires supplemental heating. For a typical house, supplemental heat is required below 65F. Some of this heat may be supplied by the occupants, appliances (cooking, lighting) and by solar gain. But, most will have to come from a dedicated heating system.

When we talk about heating systems, we use BTU's as a common measurement. BTU (British Thermal Unit) equals the heat to raise one pound of water (8.4 lbs/gallon) one degree F. This is about the amount of energy contained in a common kitchen match.

When we look at heating sources later, you will discover they have different BTU content. When evaluating them, you have to also be aware of the ability of the heating system to convert this source into usable heat.

As an example, an older furnace (identified by a metal or masonry chimney) may have an average efficiency of around 60%. That means, of the total heat contained in your fuel source, about 60% goes into your home, while 40% will be lost up the chimney. If your furnace is a newer style (these are advertised as 90-94%+) with plastic vent pipes, it may have an average efficiency of around 85%. Furnace efficiency is also referred to as "Annual Fuel Utilization Efficiency" (AFUE).

Actual operating efficiencies of furnaces can be different than advertised ratings for several reasons:

- In the real world, furnaces get out of tune, making them run less efficiently.
- Efficiency varies as to the run-time of the furnace. From a cold start, efficiency increases until it eventually hits a maximum. For most of the heating season a furnace runs for limited times (called "short-cycling"), so it doesn't warm up and consequently can't reach its maximum efficiency. Factory efficiency is measured under controlled conditions, including a steady-state operation.
- The cold, outside air taken into the combustion chamber has to be heated up by the furnace. This consumes some energy, reducing overall system efficiency.
- Inadequate design and maintenance of the air handling system can raise furnace temperatures, forcing more heat outside (change those air filters!!).

Let's look at an example of an older furnace to demonstrate these efficiency factors:

An older fuel oil furnace has a 100,000 BTU *input* rating; with an average 60% efficiency its *output* is only 60,000 BTU.

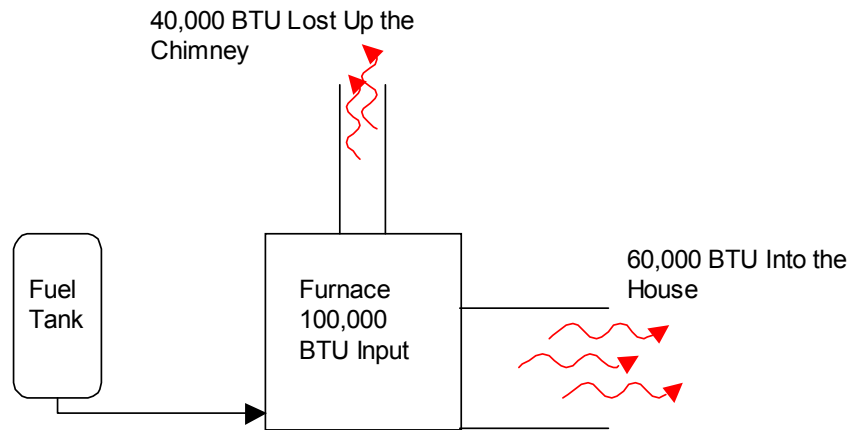

If this old furnace was replaced with a newer model of around 85% efficiency, only about a 70,000 BTU size would be required, $70,000 \text{ BTU input} \times 85\% = 59,500 \text{ BTU output}$.

A fossil fueled heating system should be sized close to the heat loss of the house. The common practice of over-sizing a furnace will always keep your house warm, but leads to “short-cycling”, reducing its overall efficiency. On the other hand, consult with a heating expert before you downsize the heating systems, otherwise you could wind up adding supplemental heat later or suffering with a cold house.

II. WHAT IS THE BEST SOURCE OF HEAT FOR YOUR HOUSE?

Heating choices are not totally about dollars and cents, but also how you want your home to look, feel and operate. The easiest home to heat would be a small, windowless foam box you would crawl into, pull the opening shut, have someone wrap it completely in plastic and then tape it shut. This isn't very healthy and is not recommended.

For a real house, you have to address such general issues as:

- How warm do you keep your home?
- Do you occupy your home all winter or travel south?
- Do you like a passive or forced air heating system?
- How much room do you want your heating system to take up?
- How obtrusive can the heating system be? (grills, noise, chimneys)
- Do you want your heating to be automatic, or do you like to adjust and/or feed it?

Maintenance

- How much maintenance does your heating system need now?
- How much will it need in the future?
- If the heating system fails in middle of night, what is your plan to repair it?

Safety

- Certain forms of heat are inherently more dangerous than others; burning wood is statistically more dangerous in terms of house fires.
- Any fossil fuel heating system can malfunction and produce dangerous levels of carbon monoxide.

Operating Cost

- How much does your present heating system really cost to operate, and what are you willing to do to reduce it's operating costs?

Each heat source has its own unique benefits and disadvantages, including operating costs. Here's a summary of some common sources of heating:

ALTERNATE (Solar and/or wind)

For practical purposes, harnessing solar energy involves opening the window blinds on south facing windows on a sunny winter day and closing the blinds on a sunny summer day. The sun can be a cheap source of heat as long as nature cooperates.

Practical wind power means orientating your house or landscaping to take advantage of prevailing winds for heating or cooling. There are numerous technical and economic roadblocks to an average homeowner using solar or wind energy to power their home. As an example, a wind powered generator capable of producing all the electricity for your home could be as expensive as the home and would work only when the wind blows. Hopefully, as technology improves, individual systems will be more feasible. You can participate in wind power now through Crow Wing Power's Green Power program.

WOOD

Btu's/cord (air dried and seasoned)

| | |
|--------------|------------|
| Rock Elm | 32,000,000 |
| White Oak | 30,600,000 |
| Sugar Maple | 29,000,000 |
| Yellow Birch | 26,200,000 |
| White Ash | 25,000,000 |
| White Spruce | 16,200,000 |

Local prices averages \$90-\$150/cord this season (delivery extra)

Wood is a locally available renewable energy source that has widely varying costs and quality. Wood needs a lot of processing (cutting, splitting, hauling) requiring specialized equipment (saws, splitters, trucks) and energy (especially yours) to use it. Wood is a steady heat source but requires some cleanup afterwards. You may find that heating with wood increases your insurance rates, making it less economical. In extreme cases, your choice in home insurance may be very limited or nonexistent because heating with wood is linked to a large number of house fires every year.

FOOD STUFF BURNERS (i.e. Corn)

7,000 Btu's/lb @ 15% moisture, 56 lb/bushel

Local prices averages \$2.30/bushel this season (#2 yellow, delivery extra)
 Similar to wood in that it is a locally available renewable energy source. Corn has to be purchased, transported to your home and stored in vermin-proof containers since corn is a food source for a number of undesirable critters. Corn is a steady heat source but requires some cleanup afterwards. Like wood, you may find that heating your house with corn affects your insurance rates, which can make it less economical. In extreme cases, your choice in home insurance may be very limited or nonexistent. Statistically, renewable fuel heating systems are linked to a large number of house fires every year.

FUEL OIL (#2) 1 gallon = 138,000 Btu's

Local prices average \$2.28/gal

National prices average \$2.41/gal (12/05/05 DOE)

Fuel oil packs a lot of heat into each gallon, making it a reasonably good heating value. It is a product of crude oil refining, with domestic production at 8 billion gallons/year.

Home fuel oil heating systems are most common on the East Coast; less common in our area. Oil heating systems do require periodic maintenance and some people object to the smell of fuel oil. Your fuel costs can and do vary during the year, but at least you have a choice of different suppliers. Recent years have seen dramatic price increases; in the Brainerd area prices have been as high as \$3/gallon.

PROPANE (LP) 1 gallon = 95,000 Btu's

Local prices average \$1.47/gal

National prices average \$1.94/gal (12/05/05 DOE)

Propane is promoted as a clean and convenient energy source. About 15 billion gallons are consumed each year. It is a product of refining crude oil and is easily liquefied, making transportation easier. It has a relatively low Btu content per gallon, so large on-site storage tanks are needed. In cold temperatures (-30 F or lower), LP gas can completely liquefy in the tank, shutting down your heating system. Delivered prices vary widely as to the season; most storage tanks are leased which tends to lock you into one supplier.

Here's a summary of average LP prices in Minnesota since 1970:

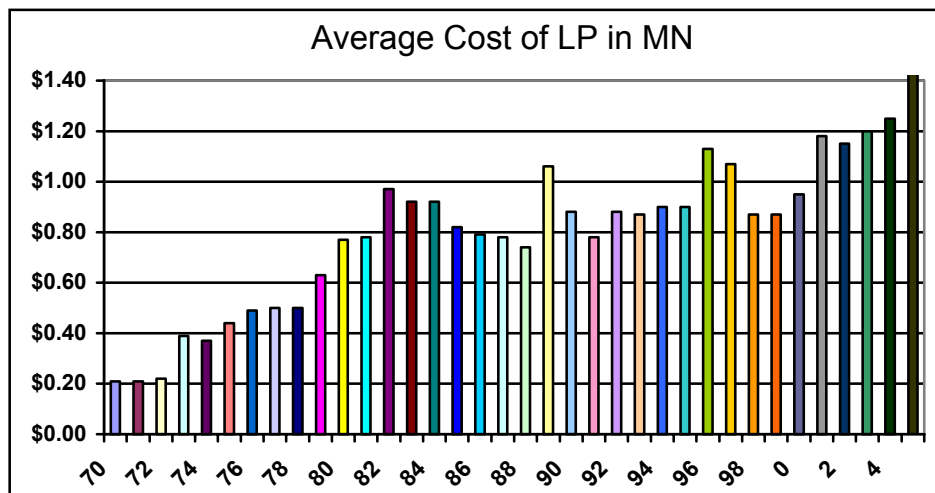

NATURAL GAS 1 therm = 100,000 Btu's

Local prices average \$1.17/therm

National prices average \$1.21/therm (12/05/05 DOE)

Promoted as a clean, economical heating source. Natural gas packs a great deal of heat, but requires a special fixed delivery system that locks you into one supplier. Recent price increases have made natural gas less attractive; the Department of Energy estimates homeowners will pay 40% more this heating season. Most suppliers have a fixed charge each month to maintain a service to your home even if you don't use any gas.

ELECTRICITY 1,000 watts = 3,412 Btu's

Crow Wing Power rates vary (depending upon interruptible rates) from \$0.069/ to \$0.035/kwh*

Electricity is not an actual source of energy; rather it is an energy delivery system. It can be made from fossil fuels, nuclear energy, hydroelectric, and renewable sources such as sun, wind and bio-fuels. Electricity can be a cheap, clean and safe means of heating your home.

*electric heating rates include PCA effective 01/02/06

ELECTRIC HEATING SYSTEMS

Electric resistance heating systems include duct (or plenum heaters), furnaces, or baseboard units. Electric heating systems achieve virtual 100% efficiency and have low installation and maintenance costs.

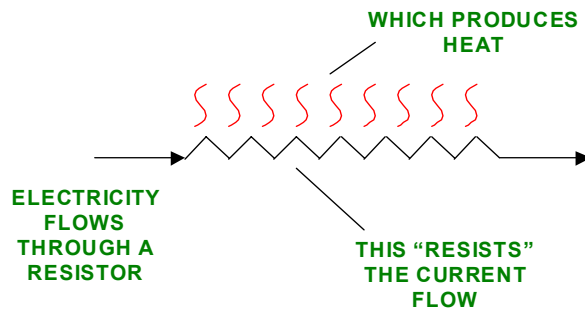

Heat Pumps don't create heat, rather they "move" heat using a refrigerant, similar to the process used in your ordinary window air conditioner. Normally, this air conditioner is arranged to pump heat out of your house to the outside.

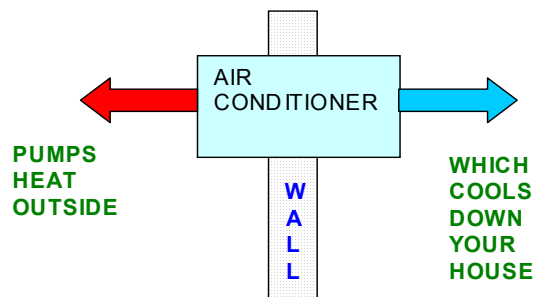

If you turned an air conditioner backwards, it could pump heat from the outside into your house. A "heat pump" is a special type of air conditioner that uses valves to control the flow of heat, saving you from lugging equipment around. Heat pumps move an average of 2 and 3 units of heat for each unit of energy input; their peak efficiencies can approach 4 units. The common source of heat is the earth, referred to as Geothermal or Ground

Source. Air Source heat pumps can also be used, but require backup heating during the winter, since extremely cold outside air doesn't provide any heating benefit.

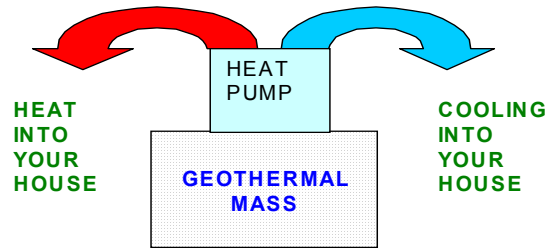

By taking advantages of interruptible electric rates, the costs of operating an electric heating system can be the same or less than a comparable fossil fuel system.

III. LOAD MANAGEMENT

Electricity has to be instantly supplied when needed and cannot be stored using any present technology. Since people tend to use electricity at their convenience, sometimes there is more capacity than usage, while at other times the usage exceeds the capacity. This greatly affects the cost of electricity. Here's "capacity" compared to "usage" on a typical winter day:

Electric Load Profile (typical)

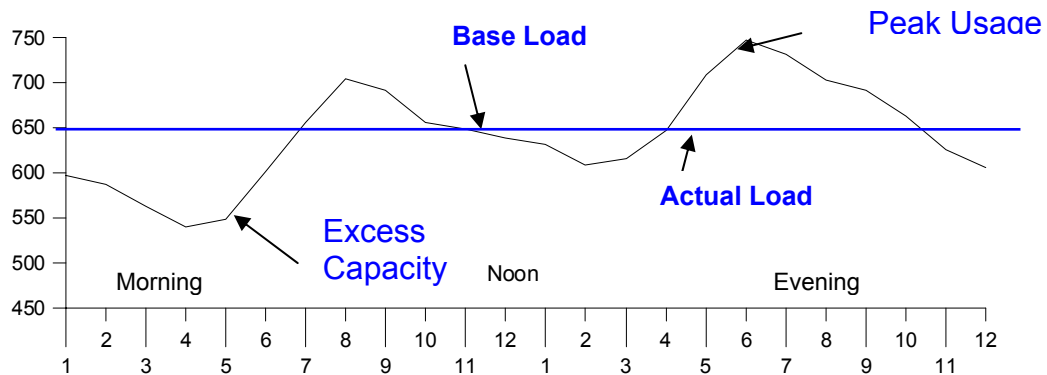

To utilize excess low-cost electric capacity available late at night and early in morning, Crow Wing Power has an **Off-Peak** program.

- These rates are 57% less than general service electricity.
- **Water and space heating** are 2 applications that qualify for this program.

To reduce electric loads during expensive peak usage times in the afternoon and early evening, Crow Wing Power has a **Dual-Fuel** program.

- These rates are **50%** less than general service rates.
- **Space Heating** in the winter (with a back-up heating source) and **Air Conditioning** in the summer, are loads that qualify for this program.

A variation of the Dual-Fuel program is called **Freedom Heating**. This controls electric loads on a limited basis during peak load times in the afternoon and early evening.

- These rates are **32%** less than general service rates.
- **Space Heating** in the winter (with a manual back-up heating source) and **Air Conditioning** in the summer, are loads that qualify for this program.

ESTIMATED HEATING COSTS, ELECTRIC VS OTHER

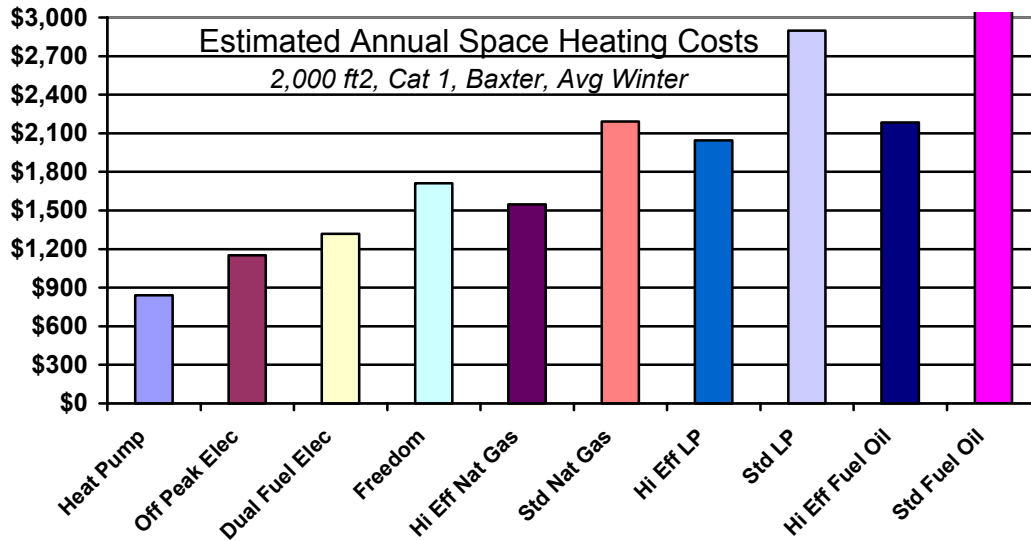

Electric heating rates include PCA effective 1-2-6
 Note: Prices do not include any tank lease, fuel delivery fees, or applicable taxes

The “Standard House” in this example has a maximum heat loss (at design temp) of 68,500 BTU/HR. Total BTU’s required in a heating season are calculated using a 20 yr average value.

FUEL COST COMPARISON

| | Off Peak \$0.035/kwh* | Dual Fuel \$0.04/kwh* | Freedom Heat \$0.052/kwh* | Heat Pump \$0.069/kwh |
|-----------------------|--------------------------|--------------------------|------------------------------|--------------------------|
| Standard Nat Gas | \$0.62/therm | \$0.71/therm | \$0.92/therm | \$0.45/therm |
| Hi Efficiency Nat Gas | \$0.86/therm | \$0.99/therm | \$1.29/therm | \$0.64/therm |
| Standard Propane | \$0.59/gal | \$0.67/gal | \$0.88/gal | \$0.43/gal |
| Hi Efficiency Propane | \$0.82/gal | \$0.94/gal | \$1.22/gal | \$0.60/gal |
| Standard Fuel Oil | \$0.84/gal | \$0.96/gal | \$1.25/gal | \$0.62/gal |

Example of Annual Savings:

You have a standard efficiency propane furnace that uses 1,000 gallons of fuel each heating season, which costs you \$1.47/gal. Compared to Dual Fuel, you would have to buy propane @ \$.67/gal to be equal.

\$1.47 (present cost)
-\$0.67 (electric equivalent)
 = \$.80/gal saved
x 1,000 gallons used
 = **\$800 estimated annual savings.**

HEATING TERMS

BTU (British Thermal Unit) = heat to raise 1lb water 1 degree F, 8.4 lb/gallon water

Electricity 1,000 watts = 3,412 Btu's

Natural Gas 1 therm = 100,000 Btu's

Propane 1 gallon = 95,000 Btu's

Fuel Oil (#2) 1 gallon = 138,000 Btu's

Average Person adds 550 Btu/hr to interior space (office setting)

CRUDE OIL SUPPLIES

Current worldwide production is about 82 million barrels per day, projected to increase by about 2 million/day each year. Most of this increase will come from developing nations, notably China and India. Increases in both production and consumption are closely tied with economics and politics, and are difficult to predict.

With improvements in recovery technology, both proven and anticipated oil reserves are projected to handle world-wide demand through 2025. However, demand for oil has recently matched production, leading to volatile pricing.

There is no general consensus as to when the oil runs out.

Department of Energy, "Strategic Energy Outlook 2003"

Electricity:

Volts x amps = watts (also) watts/volts = amps

1000 watts = 1 kilowatt

1000 watts used in 1 hour = 1 kilowatt hour (kWh)

To fuse heating circuits, usually derate by 80% from calculated load.

1500 watt electric heater / 120 volts = 12.5 amps / 80% = 15.6 amp fuse

Information Sources:

MN Dept of Public Service at <http://www.state.mn.us/cgi-bin/portal/mn/jsp/content.do?subchannel=-536881511&id=-536881350&agency=Commerce>

Department of Energy at www.energy.gov/house/index.html

Minnesota State Board of Electricity at www.electricity.state.mn.us/

Financing:

Many banks offer energy efficient mortgages, with reduced financing rates for houses meeting certain efficiency standards. Homes built to meet or exceed Minnesota's current energy code may qualify. Your lending agency will have details on this program.

Sometimes 3rd party certification is required. You can get more details at:

www.natresnet.org Residential Energy Services Network

www.fanniemae.com Fannie Mae @ 1-800-732-6643

www.hud.gov Department of Housing and Urban Development